

HAFCO METALMASTER DMF-44



Pedestal Mill Drill - Geared & Tilting Head

(X) 480mm (Y) 200mm (Z) 850mm



HAFCO METALMASTER DMF-44 Pedestal Mill Drill - Geared & Tilting Head



Tilt Head Full View



Left View



Rear Left View



Rear Right View



Milling Head



Mill Head Close Up



Control Panel with Tapping Function



Geared Spindle Speed Dials



Adjustable Drilling Depth Stop



Quill Lock Lever

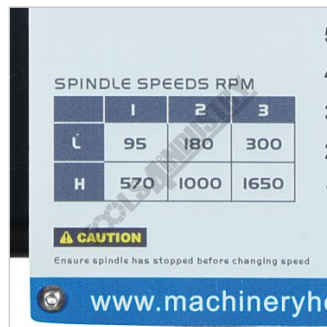

6 Drilling Speeds 95 ~ 165rpm



Swivel Safety Drilling Chuck Gaurd



Rack & Pinion Wind Up Drill Head



Rack & Pinion Wind Up Table



Quill Handle



Quill Micro Fine Feed Dial

HAFCO METALMASTER DMF-44 Pedestal Mill Drill - Geared & Tilting Head



Heavy Duty Motor



Draw Bar For Milling



Flexible Coolant Hose



Table with Coolant Return Hose

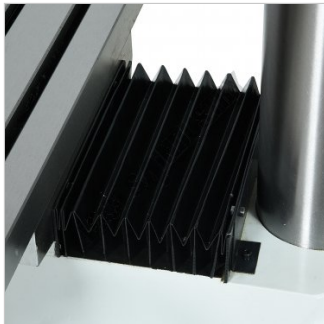

Concertina Rear Slide-Way Cover



Tilting Head $\pm 90^\circ$



Head Tilted To 45°



Main Isolation Switch



Table Longitudinal Dial



Table Cross Feed Dial

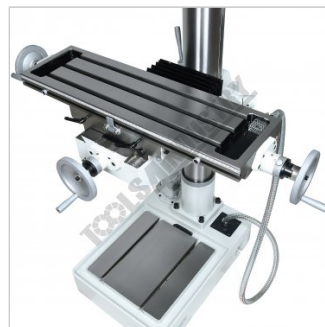

T Slotted Work Table & Base

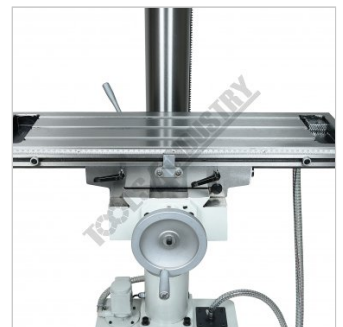

Work Table with Length Stops



T Slotted Base



Coolant Pump System



Coolant Pump



Milling Cutter

HAFCO METALMASTER DMF-44 Pedestal Mill Drill - Geared & Tilting Head



Included Parts

Features

- Ideal for home or light industrial workshop use
- Geared head drill & mill machine with 3 morse taper spindle
- 6 drilling speeds from 95-1650rpm
- Thread tapping function
- Coolant pump system with flexible hose
- Micro down feed adjustment
- Mill head tilts to $\pm 90^\circ$
- Milling table travels 480 x 200mm
- Swivel safety drilling chuck guard
- Emergency stop switch and overload protection
- Adjustable accurate depth setting for increased productivity
- Rack and pinion wind-up table
- Rack and pinion wind-up drill head
- Thick walled column ensuring greater rigidity
- Concertina slide way cover on y axis
- Adjustable gibs on table
- 14mm T slotted work table and base
- 1.5kW 240V motor

Includes

- Face milling cutter with inserts
- 13mm keyed drill chuck and arbor
- Chuck key to suit
- MT3 to MT2 drill sleeve adapter
- Drill drift tool to remove drill chuck or taper shank drills
- 1 x M12 x 1.75mm drawbar
- 1 x 1/2" x 12TPI drawbar
- Safety cutter guard



HAFCO METALMASTER DMF-44 Pedestal Mill Drill - Geared & Tilting Head

Specifications

ORDER CODE	D185
MODEL	DMF-44
Digital Readout	Optional
Type	Vertical
Table Size (mm)	730 x 210
Column Type	Ø125mm
Spindle Taper - Vertical	3MT
Spindle Taper - Horizontal	~
Longitudinal Travel (X-Axis) (mm)	480
Cross Travel (Y-Axis) (mm)	200
Vertical Travel (Z-Axis) (mm)	850
Type of Slides	Dovetail
Ram Travel (mm)	~
Spindle to Table (mm)	850
Spindle Travel / Diameter (mm)	120 / 75
Throat Depth (max.) (mm)	280
Tilting Head (Left ~ Right)	±90°
Tilting Head (Forward ~ Back)	Fixed
Drilling Capacity (mm)	31.5
End Milling Capacity (mm)	28
Face Milling Capacity (mm)	80
Power Feed - Quill (mm/rev)	~
Power Feed - Longitudinal (X-Axis) (mm/min)	Optional
Power Feed - Cross (Y-Axis) (mm/min)	~
Power Feed - Vertical (Z-Axis) (mm/min)	~
Table T-Slot Size (inch / mm)	14
Work Table Load Capacity (kg)	55
Spindle Speeds Vertical (No./ rpm)	6 (95 - 1650)
Spindle Speeds Horizontal (No./ rpm)	~
Motor Power - Vertical (kW / hp)	1.5 / 2
Motor Power - Horizontal (kW / hp)	~
Voltage / Amperage (V / amp)	240 / 10
Shipping Dimensions (L x W x H) (cm)	84 x 74 x 198
Nett Weight (kg)	350